



DLS Reference series

RMW 10 & RMW12

Car Audio subwoofers

Welcome

Thank you for buying a DLS Reference subwoofer. The subwoofer must be installed correctly in order to work well. This manual will show you how to install it like a pro. Please read the entire manual before beginning the installation. Install the subwoofer yourself if you feel confident with our instructions and if you have the proper tools. However if you feel unsure, turn over the installation job to someone better suited to it.

The speakers are designed for enclosure mounting. In "open air" installations the power handling capacity is reduced by 30% from the nominal value. We don't recommend "open air" installations for Reference subwoofers.

Connection of subwoofer

How to connect depends on what type of amplifier you use. The best is to follow the instructions given in the manual for the amplifier. Most amplifiers today have built-in lowpass crossover and possibilities to connect your subwoofer in bridge mode. Two 4 ohm subwoofers are often connected in stereo mode since most amplifiers can't handle bridge mode loads below 4 ohms.

Make sure to connect in ways that don't ruin the amplifier. If you have a DLS Ultimate amplifier it's possible to connect the two subwoofers in parallel, these amplifiers are 1 ohm stable.

We also recommend the use of a subsonic high pass filter. This gives a better bass reproduction with less "rumble". In most DLS amplifiers this feature is already built-in. For wiring use high class speaker wires, min AWG11 (4 mm²). For example **DLS SC 2x4**.

Enclosure damping

Most enclosures should be damped inside with synthetic (acoustic) wool or damping mat (line). Attach the damping material on the wall opposite from the speaker and port. In a vented enclosure the speaker and port should be on the same side, otherwise a fade-out of some frequencies can occur. In most vehicles, except for SEDAN cars, the speaker and port should be directed backwards for best result.



Technical Assistance

For technical assistance ask the shop where the product was sold or the distributor in your very country. You can always contact the DLS Helpdesk in Sweden on e-mail : info@dls.se Information can also be found on our WEB-site www.dls.se

We follow a policy of continuous advancement in development. For this reason all or part of specifications & designs may be changed without prior notice.

Subwoofer enclosures, general

Build your enclosure in a stable and airtight material. The best is MDF-board, 19 mm, or particle board, 22 mm. Larger enclosures must have bracing inside to avoid vibrations. The enclosure must be completely airtight. Use sealing compound in all joints, also around the cable terminals. The size of the enclosure is decided by the speaker data.

Vented enclosures

A speaker in a vented enclosure has a higher efficiency (+3 dB) and higher power handling capacity than in a sealed enclosure. In a vented enclosure the sound from the speaker and the port work together creating a higher sound level. The sound from the port must come out in the same phase as from the speaker otherwise the result is bad.

The size of the vented enclosure is decided by the speaker data just as for the sealed one.

The size of the vehicle often decides the practical size of the enclosure. A smaller enclosure has a higher resonant frequency than the larger one. The size of the enclosure should not be so big that the speaker plays below it's own free air resonance (Fs), then it will loose in power handling capacity.

The port does not have to be fully inside the enclosure as long as the area and length are correct. Sometimes you need two or more ports in an enclosure. You can convert from one to two or more ports as long as the total port area is the same. RMW10 & RMW12 works best in vented enclosures. We don't recommend sealed enclosures for these subwoofers.

Important

Think of the speaker weight when you do your install. Use heavy bolts when fastening the sub to the enclosure baffle.

Break-in period

Allow the speaker to play for at least 15-20 hours. After this time the performance is correct.

Warranty service

This speaker is covered by warranty, depending on the conditions in the country where it is sold. If the speaker is returned for service, please include the original dated receipt with the product.



DLS Svenska AB

P.O. Box 13029
SE-40251 Göteborg, Sweden
Tel: +46 31 840060
Fax: +46 31 844021
E-mail: info@dls.se
www.dls.se

Technical specifications for DLS Reference RMW10

RMW10		Single voice coil	
Art.no	10-21410	Re, DC-resistance	3,3 ohm
Size	25 cm (10")	BL product	11,5
Impedance	4 ohm	Sensitivity (SPL 1W/1m)	87,2 dB
Nom. power (RMS)	400 W (max 600)	Resonant freq. (Fs)	35,8 Hz
Freq. range	25 Hz - 2 kHz	Vas (litre)	38,5
Voice coil, diameter	75 mm (3")	Vas (ft ³)	1,36
Voice coil, length	20 mm (0,79")	Qms	3,07
X-max	+9 mm (0,35")	Qes	0,53
Cms	205	Qts	0,45
SD	366 cm ²		
Cone material	Aluminium one cone body		
Magnet weight	50 oz (1,42 kg)		
Magnet, diameter	156 mm (6,14")		
Installation depth	125 mm (4,92")		
Mounting hole	236 mm (9,29")		
Outer diameter	266 mm (10,47")		
Weigth	5,3 kg (11,68 lbs)		

Technical specifications for DLS Reference RMW12

RMW12		Single voice coil	
Art.no	10-21412	Re, DC-resistance	3,5 ohm
Size	30 cm (12")	BL product	17,5
Impedance	4 ohm	Sensitivity (SPL 1W/1m)	93,5 dB
Nom. power (RMS)	400 W (max 600)	Resonant freq. (Fs)	39,8 Hz
Freq. range	20 Hz - 2 kHz	Vas (litre)	64,9
Voice coil, diameter	75 mm (3")	Vas (ft ³)	2,29
Voice coil, length	20 mm (0,79")	Qms	3,16
X-max	+9 mm (0,35")	Qes	0,28
Cms	162	Qts	0,26
SD	531 cm ²		
Cone material	Aluminium one cone body		
Magnet weight	140 oz (3,97 kg)		
Magnet, diameter	180mm (7,09")		
Installation depth	153 mm (6")		
Mounting hole	282 mm (11,1")		
Outer diameter	313 mm (12,32")		
Weigth	9,7 kg (21,3 lbs)		

About the recommended enclosures

The performance of these recommended enclosures will vary from vehicle to vehicle. It is more difficult to get a tight and well defined bass in a SEDAN vehicle because of the tightness between trunk and interior. In most cases the recommended enclosures on next page is the best choice. The vented box is to be preferred.

- The given enclosure volume is the inner volume.
- Volumes occupied by speaker and ports have already been added to the given enclosure volumes so don't add any more volume.
- Use DLS bass port kits for best result.

There are two flanges coming with this kit. The larger one is for the outside, and the smaller one should be attached to the tube inside the enclosure.

Make a round hole in the box where you want to mount the bass port.

The larger flange should be attached to the outside of the box. Fasten it to the box with screws or with some glue. There are prepared drill holes on the back of the flange. The smaller flange is for the inner end of the tube. Use a PVC-glu to attach it to the tube. Then glue the tube to the port mounted in the box. Use sealing compound round the flange to make the box as airtight as possible.

Enclosure placing in vehicles

In **small vehicles** like VW Golf, Peugeot 206, 306 and similar the bass box should be installed with both speaker and port directed backwards. Alternatively booth speaker and port can be directed upwards. This way of mounting is valid for all types of vehicles where the trunk is incorporated with the inner compartment.

In **sedan vehicles** with the passenger compartment separated from the trunk, the enclosure should be installed with booth speaker and port directed towards the rear seat. Some cars have an opening in the middle of the rear seat for loading skis etc. You can install the enclosure behind this opening and direct speaker or port through this opening. There must be some free space in front of the port, (between the rear seat and the port opening).

In **large vehicles** like station wagons the best sound is achieved with the enclosure installed behind the rear seat with booth speaker and port directed backwards. Alternatively you can install the enclosure on one side of the luggage compartment.

Calculate your own enclosure

Box volumes:

When calculating the inner volume of an enclosure you just multiply the width (W) x height (H) x depth (D).

Use measures in dm and you will get the answer in litres.

A trapezoid box is calculated as this:

$$\text{Vol} = \frac{\text{width (W)} \times \text{height (H)} \times (\text{upper depth (UD)} + \text{lower depth (LD)})}{2}$$

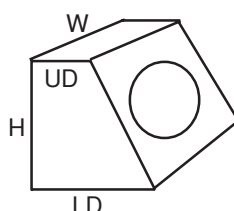

Be sure to measure the inside dimensions.

Recommended enclosure RMW10

Vented enclosure:

Wiring : Single voice coil
 Volume : 26 / 0,92 (litre / ft³)
 Port* : 3"(6,8 cm) x 20 cm / 7,87"
 Damping : Line inside
 F3 : 45,8 Hz

* Use the BP 75 port kit coming with the subwoofer. The tube is already cut to it's correct length.

Outside box dimensions:

Width : 500 mm (19,69")
 Height : 320 mm (12,60")
 Lower depth : 288 mm (11,33")
 Upper depth : 188 mm (7,4")
 Material : MDF 19 mm (3/4")

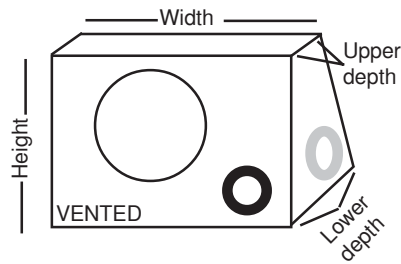

For best result, use the recommended enclosure.

If you want to modify the dimensions, use the calculation methods described on previous page. As an alternative the port can also be mounted on the side of the enclosure.

Technical drawing for a 26 litre enclosure.

The RMW10 works well in a 26 litre vented enclosure. Here is the drawing for the box and the separate boards needed to build a suitable enclosure.

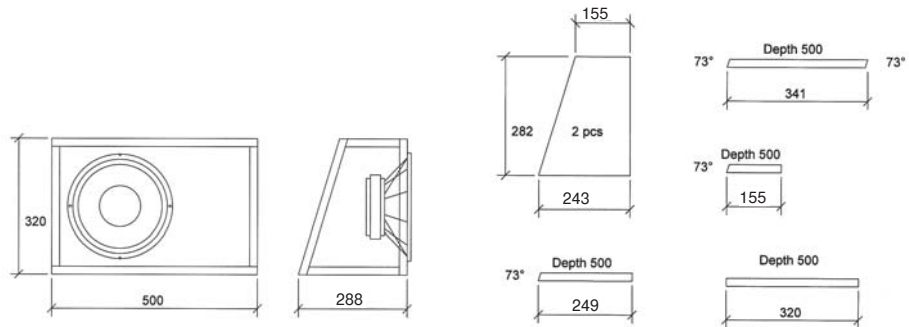

Recommended enclosure RMW12

Vented enclosure:

Wiring : Single voice coil
 Volume : 35 / 1,24 (liter / ft³)
 Port* : 4"(10,2 cm) x 20 cm / 7,87"
 Damping : Line inside
 F3 : 54 Hz

* Use the BP 110 port kit coming with the subwoofer. The tube is already cut to it's correct length.

Outside box dimensions:

Width : 550 mm (21,65")
 Height : 350 mm (13,78")
 Lower depth : 307 mm (12,09")
 Upper depth : 207 mm (8,15")
 Material : MDF 19 mm (0,75")

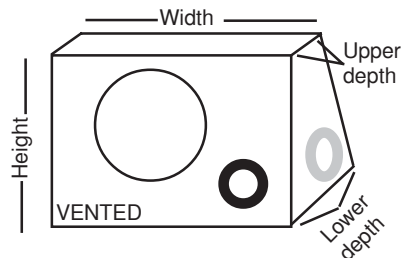

For best result, use the recommended enclosure.

If you want to modify the dimensions, use the calculation methods described on previous page. As an alternative the port can also be mounted on the side of the enclosure.

Technical drawing for a 35 litre enclosure.

The RMW12 can work well in a 35 litre vented enclosure. Here is the drawing for the box and the separate boards needed to build a suitable enclosure.

